



PARTNERSHIPS IN PRACTICE



CERADISC

Return Idler and Belt Life Multiplier

In a belt conveyor the return roller are provided to carry the belt and do not allow it to sag. During operation after the material is discharged ideally there should not be any material sticking to the return belt surface. Seldom that happens and some fine particles stick to the return belt especially when the material conveyed is sticky or contains moisture in it. In case the material is abrasive it causes wear of the surface of the return roller causing premature failure and requiring frequent replacement of the rollers. Also The uneven scales due to deposition brings into forces that leads to severe mis-tracking which eventually leads to the belt edge damage.

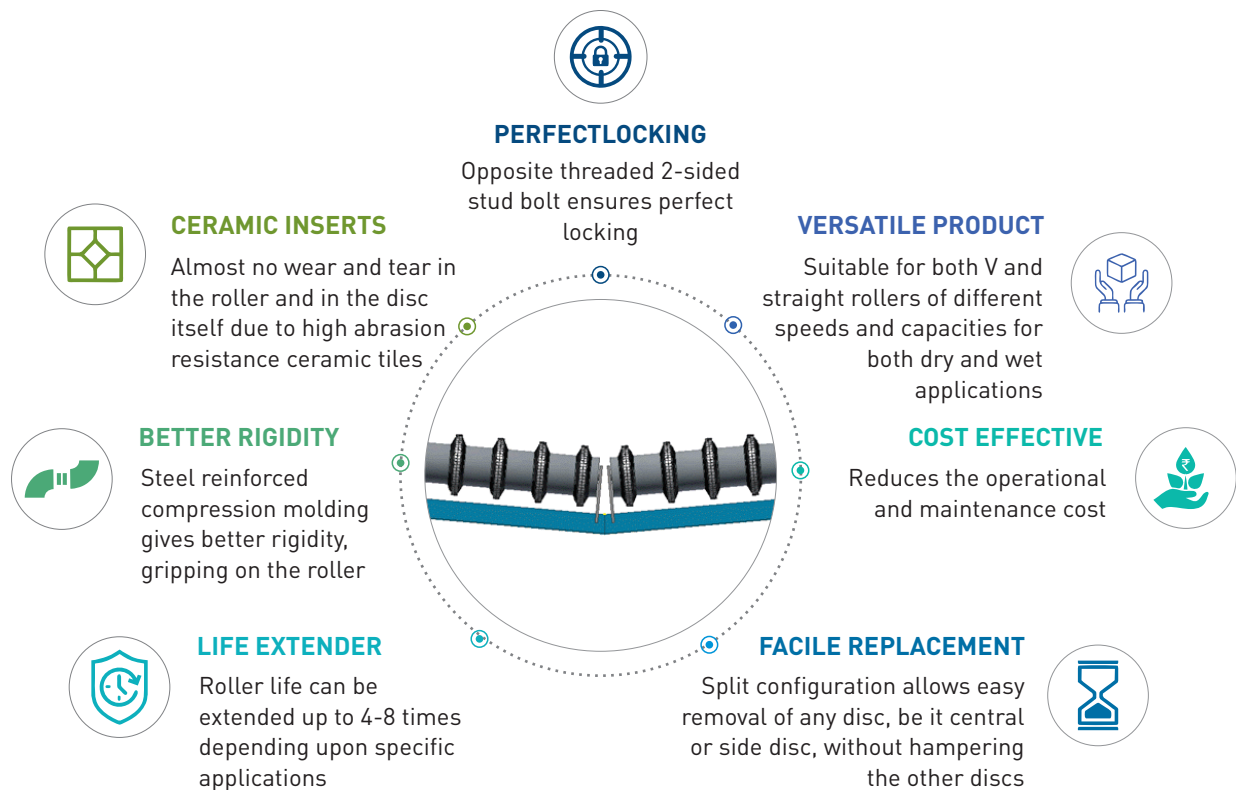

PRODUCT SPECIFICATION

TYPE	ID	OD	WIDTH
A	89	159	52
B	139	205	52
C	192	250	52
D	108	159	52
E	89	133	52
F	133	193.7	52
G	152	223	52

FUNCTIONING

The mounted Ceradisc will ensure that the belt will always be in touch with the Ceradisc and not with the return roller. It will be in a perfect lock with the roller and there will be no relative movement between the roller and the Ceradisc. The outer surface of the disc is made of ceramic tiles which will resist high wear and tear. The spacing between the discs allows the carry back to disengage from the belt.

DIMENSION SHEET FOR V and STRAIGHT RETURN ROLLER

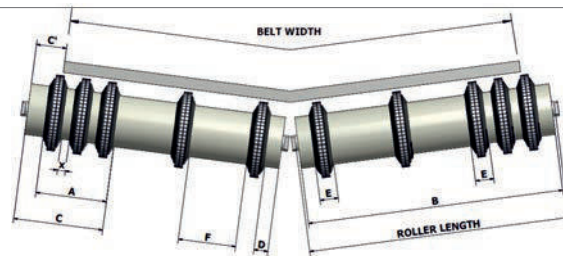

BELT WIDTH	B	ROLLER LENGTH	A	X	D	E	F	C	C'	SIDE DISC	CENTRAL DISC	TOTAL DISC
650	380	388	104	0	20	52	50	156	65	2	2	4
800	465	473	156	0	25	52	68	200	75	3	2	5
1000	600	608	176	10	25	52	58	246	110	3	3	6
1200	700	708	208	0	30	52	90	246	110	4	3	7
1400	800	808	208	0	45	52	112	260	110	4	3	7
1600	900	908	208	0	40	52	101	246	110	4	4	8
1800	1000	1008	208	0	35	52	91	246	110	4	5	9
2000	1100	1108	208	0	30	52	85	246	110	4	6	10
2200	1250	1258	260	10	40	52	92	346	160	5	6	11

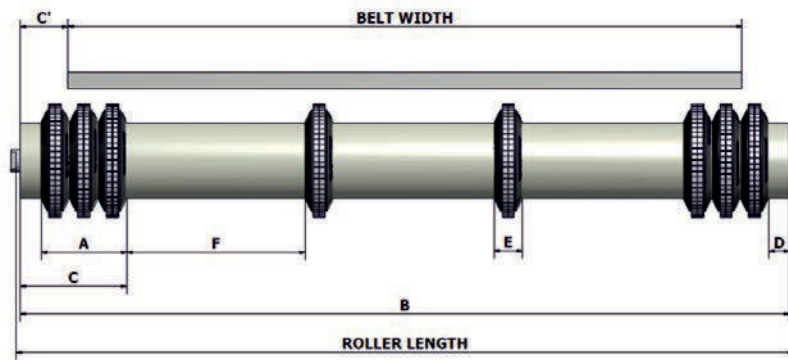

BELT WIDTH	B	ROLLER LENGTH	A	F	D	E	C	C'	SIDE DISC	CENTRAL DISC	SIDE DISC	TOTAL DISC
650	750	758	104	86	22	52	126	50	2	3	2	7
800	950	958	156	110	20	52	176	75	3	3	3	9
1000	1150	1158	156	108	20	52	176	75	3	4	3	10
1200	1400	1408	156	91	70	52	226	100	3	6	3	12
1400	1600	1608	208	106	62	52	270	100	4	6	4	14
1600	1800	1808	208	112	62	52	270	100	4	7	4	15
1800	2000	2008	208	116	62	52	270	100	4	8	4	16
2000	2200	2208	208	119	62	52	270	100	4	9	4	17
2200	2500	2508	260	120	66	52	326	150	5	10	5	20

Note: Total no of discs may vary according to Site requirements.



Tega Industries Limited

147, Block G, New Alipore, Kolkata 700 053,
 Ph: +91 33 3001 9000 | 2396 3512 | 2396 3515, Fax: +91 33 2396 3649
 Email: info@tegaindustries.com, Web: www.tegaindustries.com